

SYSTEM WIRING DIAGRAMS
Condenser Cooling Fan Circuit
1989 Suzuki Swift

cdr@wp.pl

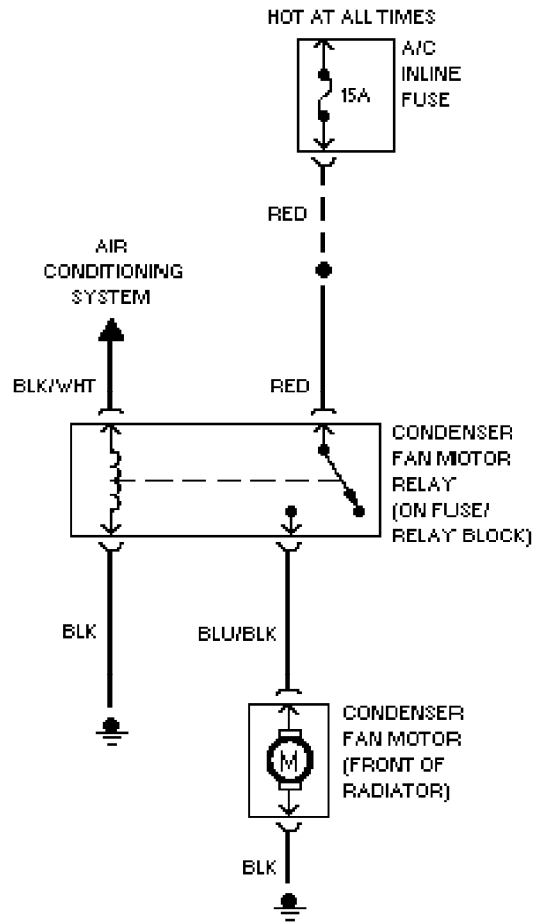

SYSTEM WIRING DIAGRAMS

Cooling Fan Circuit (p. 2)

1989 Suzuki Swift

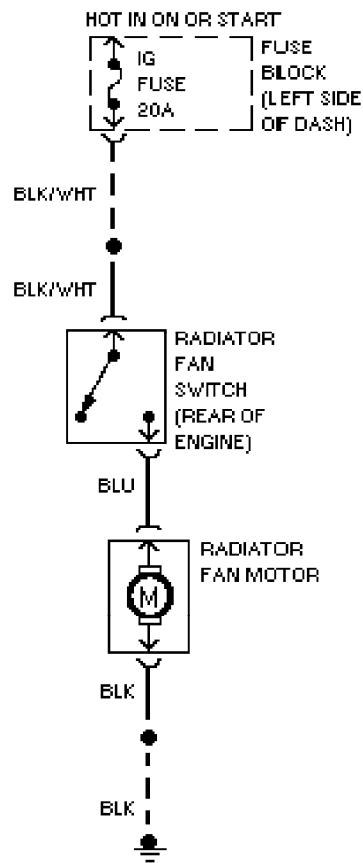

SYSTEM WIRING DIAGRAMS

Defogger Circuit (p. 3)

1989 Suzuki Swift

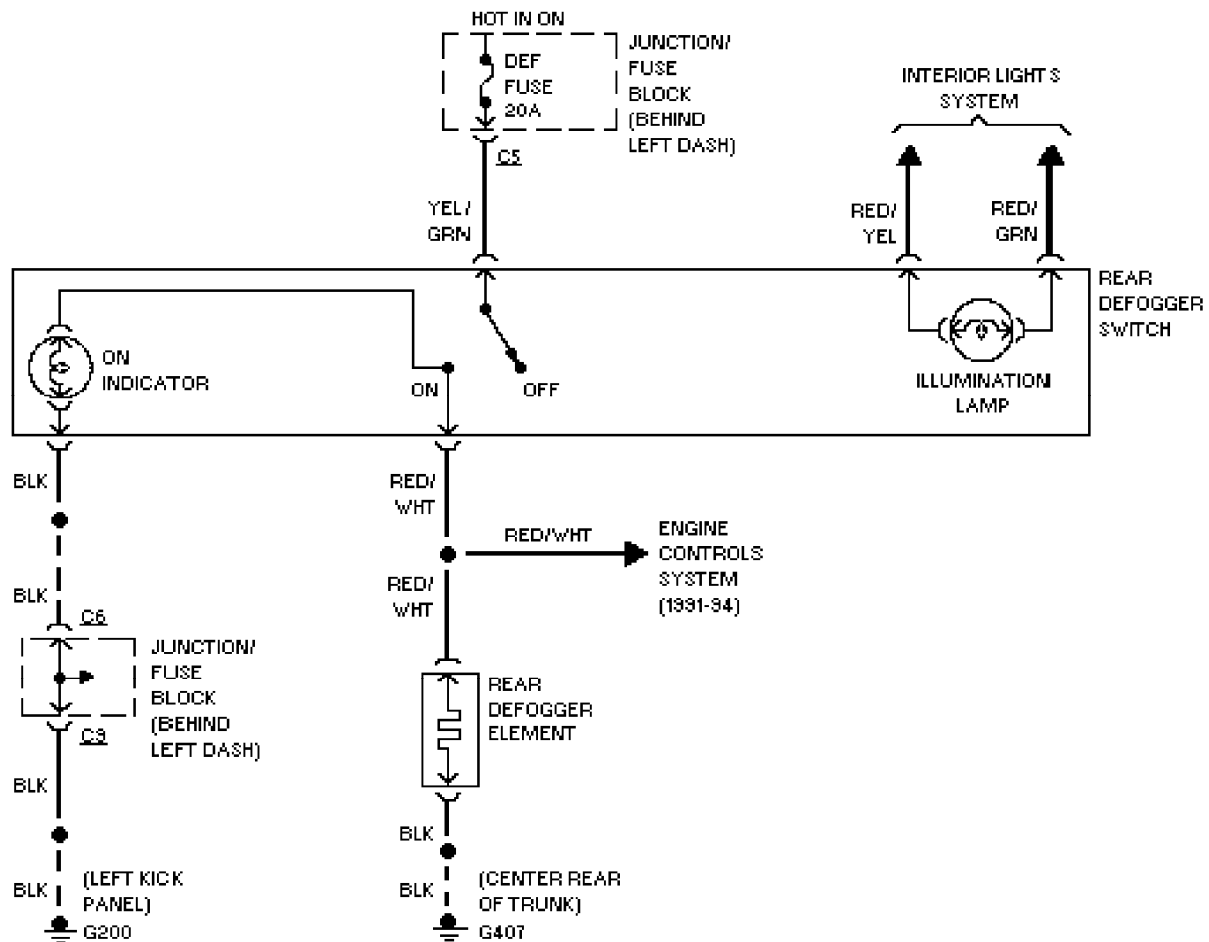

SYSTEM WIRING DIAGRAMS

Horn Circuit (p. 4)

1989 Suzuki Swift

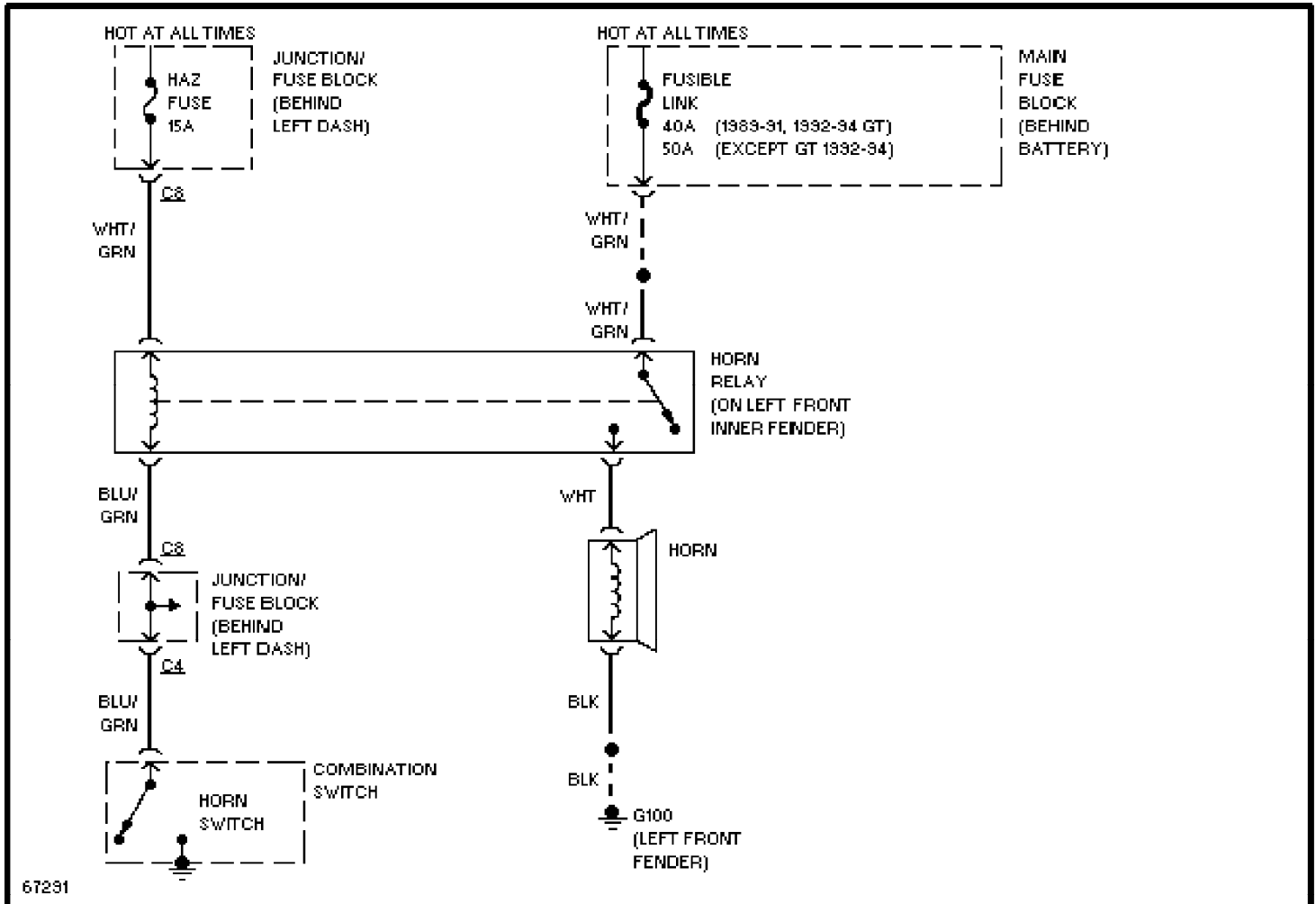

SYSTEM WIRING DIAGRAMS

Power Mirror Circuit (p. 5)

1989 Suzuki Swift

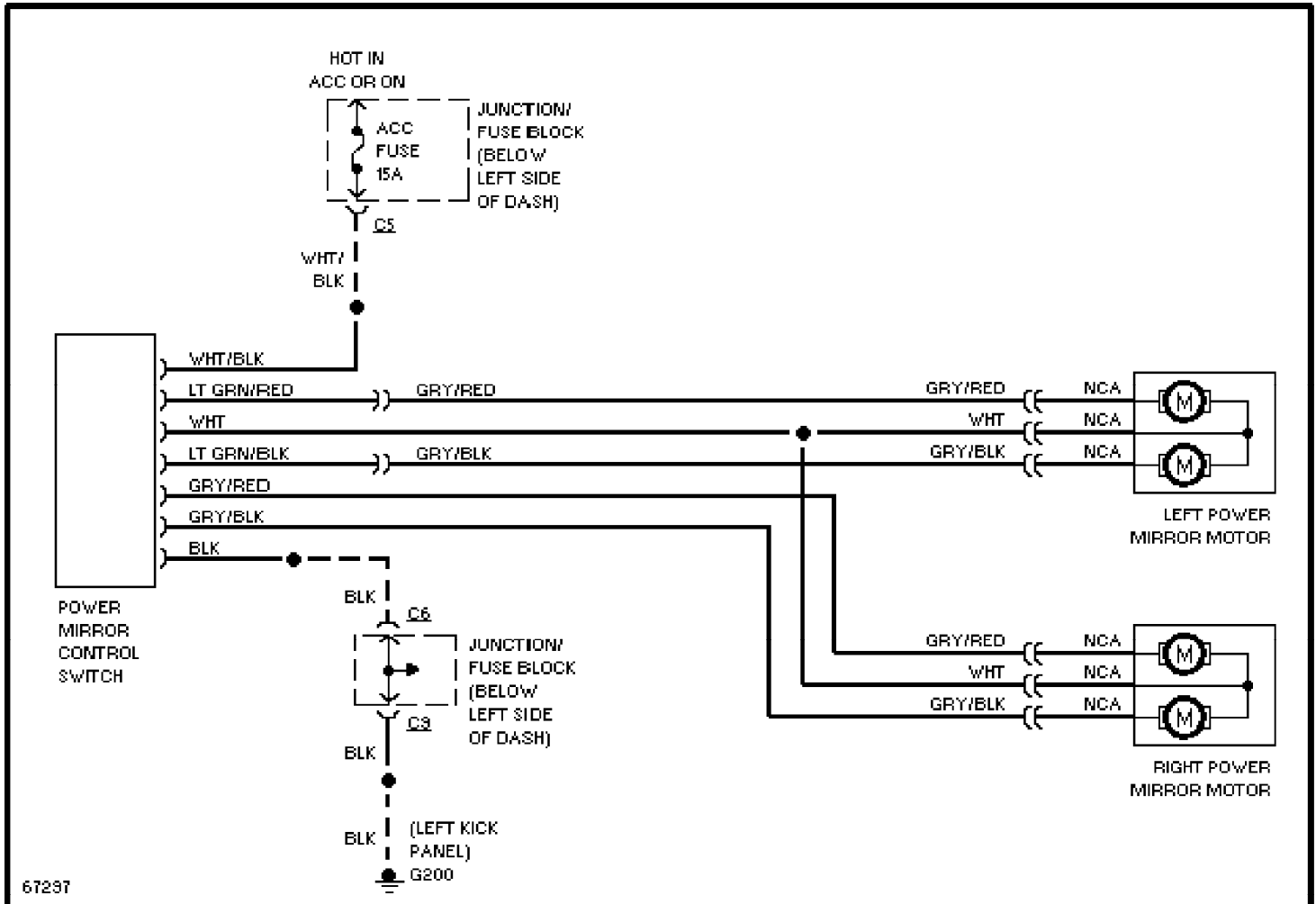

SYSTEM WIRING DIAGRAMS

Radio Circuits (p. 6)

1989 Suzuki Swift

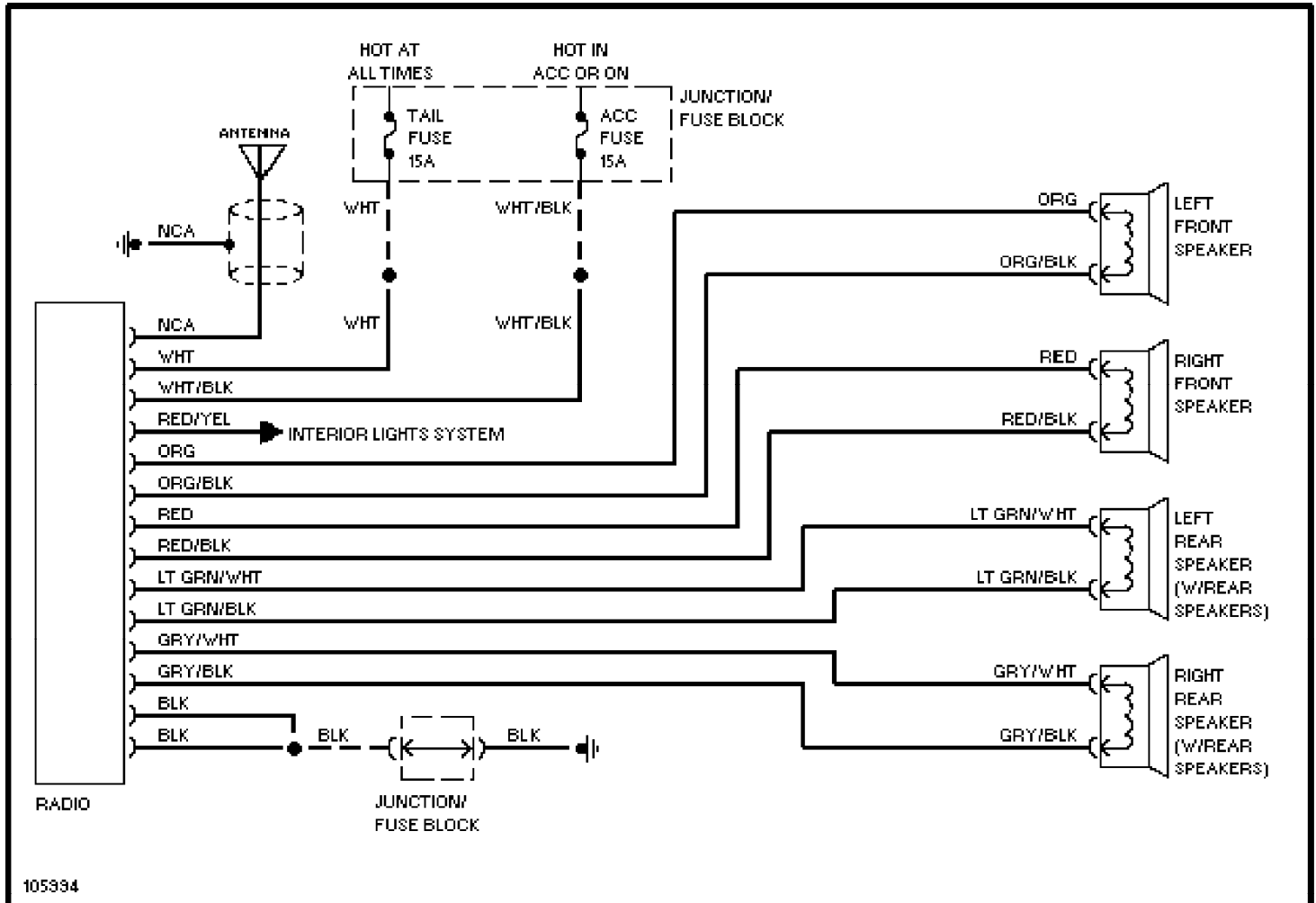

SYSTEM WIRING DIAGRAMS

Charging Circuit (p. 7)

1989 Suzuki Swift

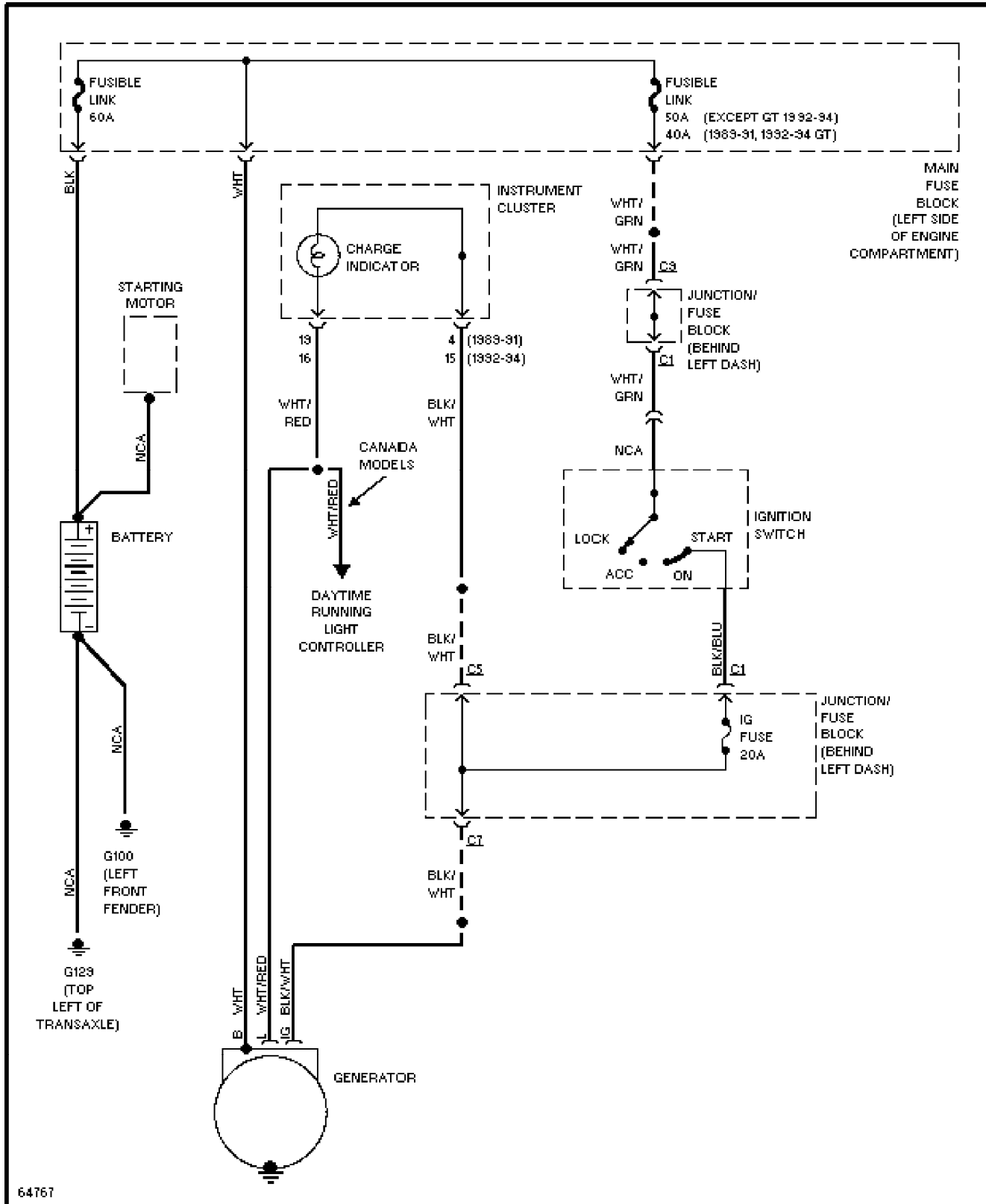

SYSTEM WIRING DIAGRAMS

Starting Circuit (p. 8)

1989 Suzuki Swift

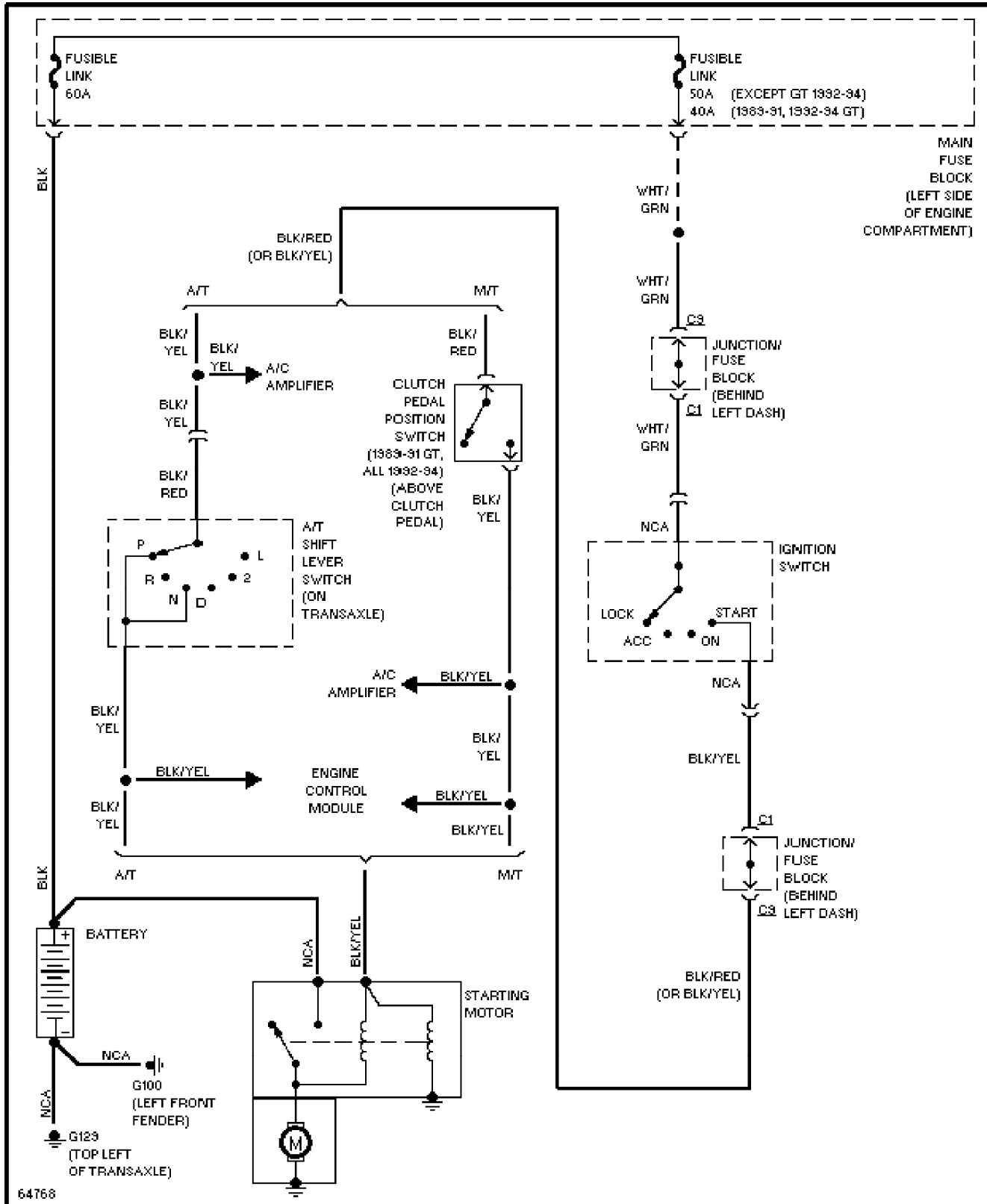

SYSTEM WIRING DIAGRAMS

Front Wiper/Washer Circuit (p. 9)

1989 Suzuki Swift

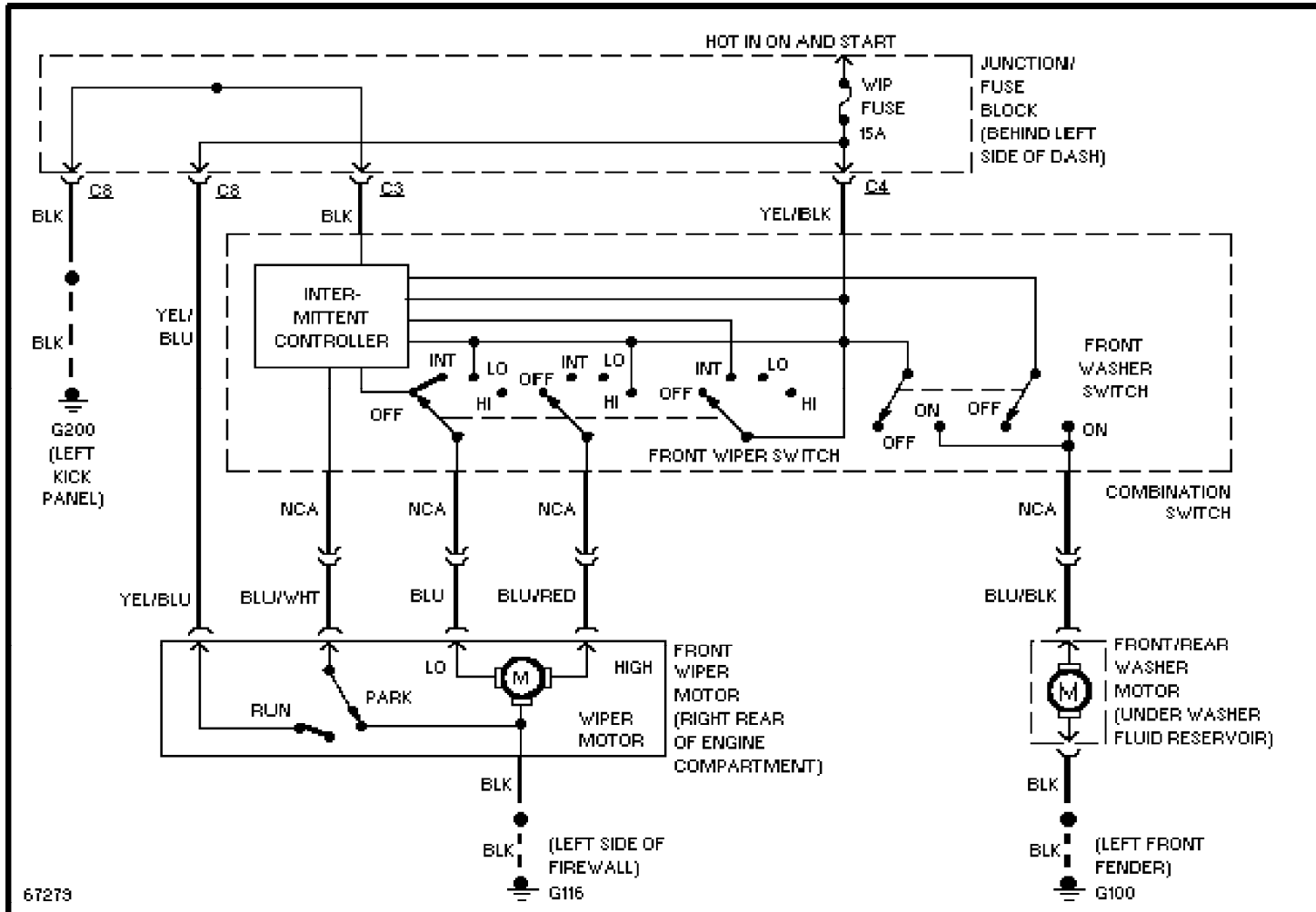

SYSTEM WIRING DIAGRAMS

Rear Wiper/Washer Circuit (p. 10)

1989 Suzuki Swift

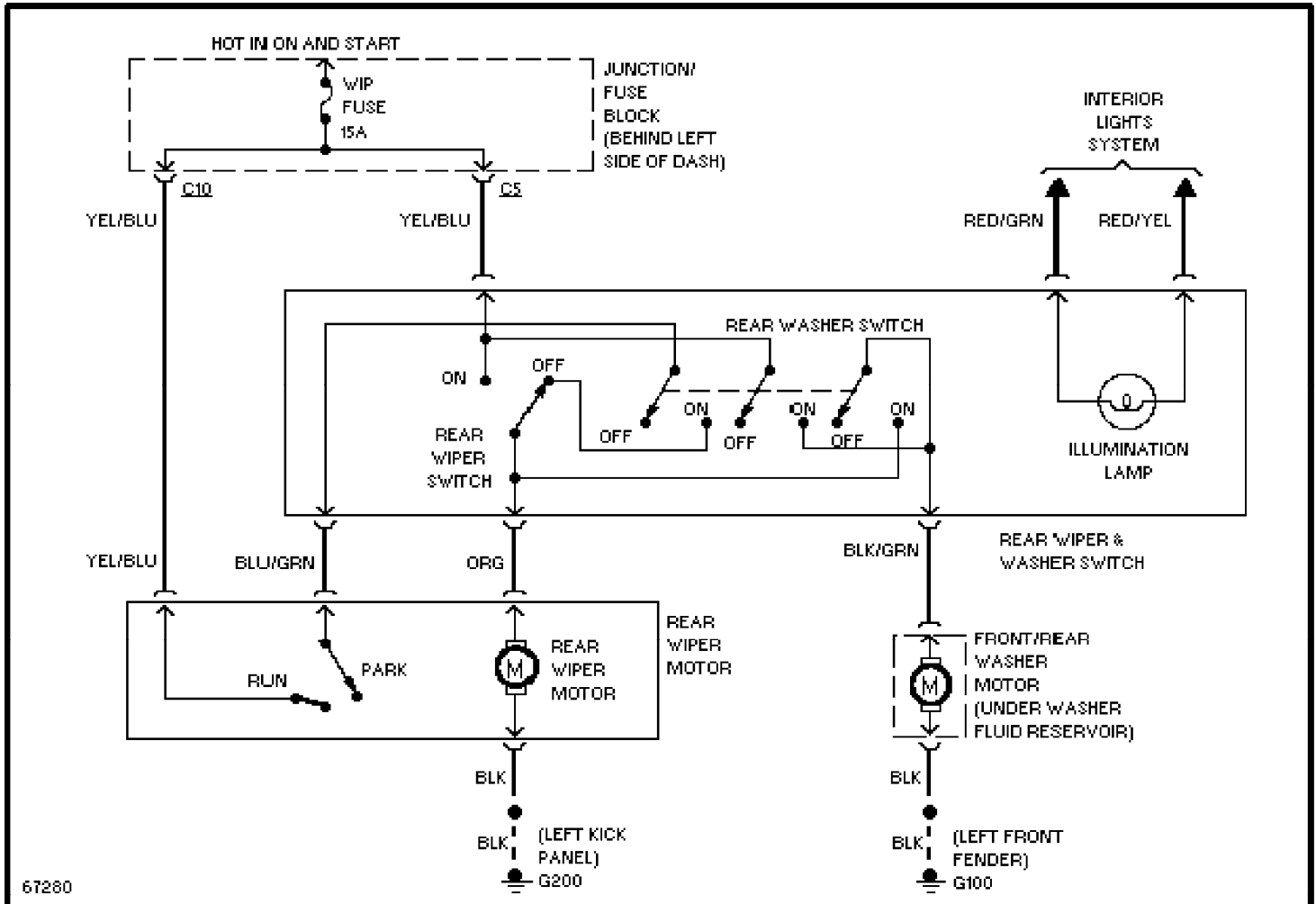

WIRING DIAGRAMS
Fig. 1: Engine Compartment & Headlights
 1989 Suzuki Swift

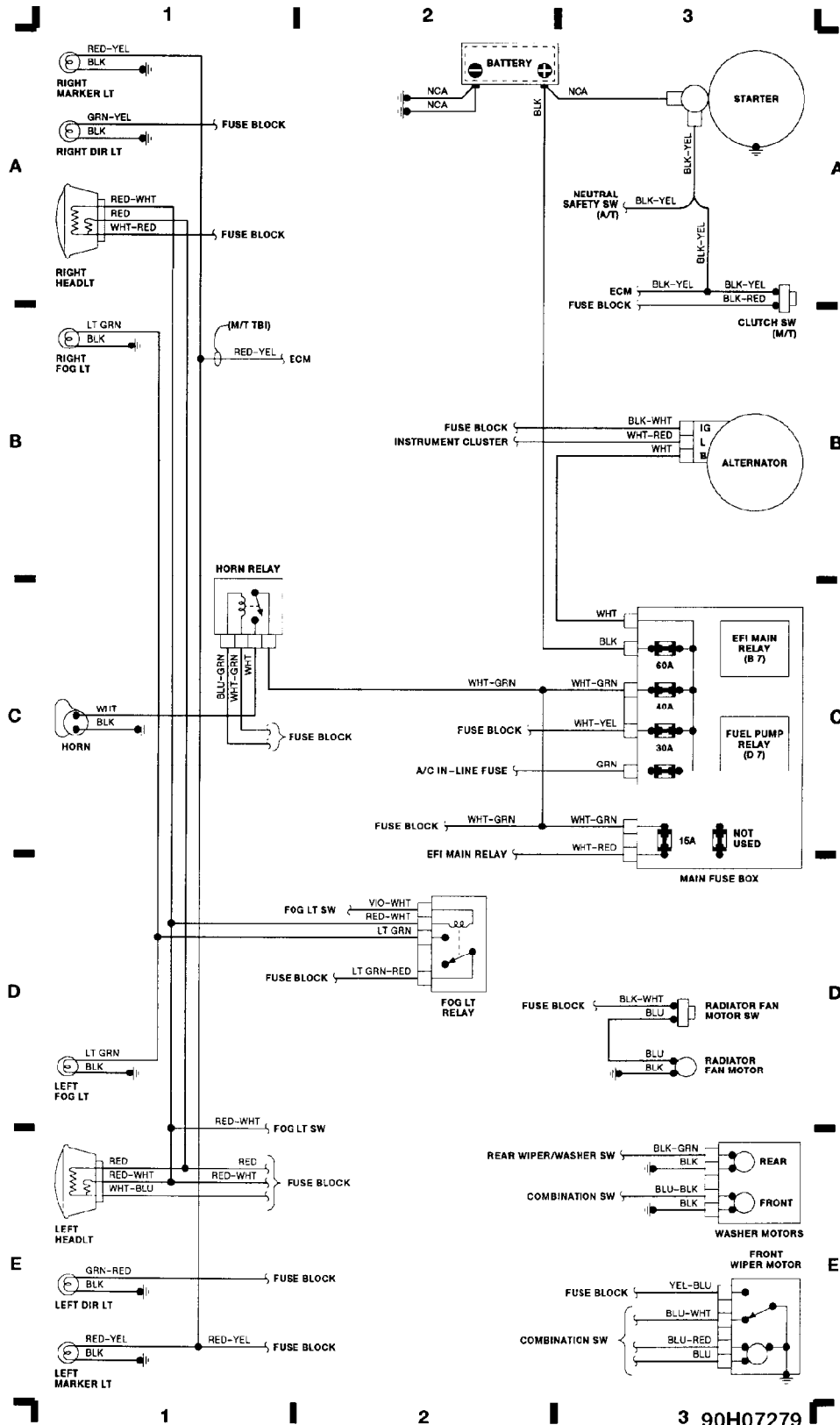

WIRING DIAGRAMS
Fig. 2: Computer Engine Control (MPFI) (p. 2)
 1989 Suzuki Swift

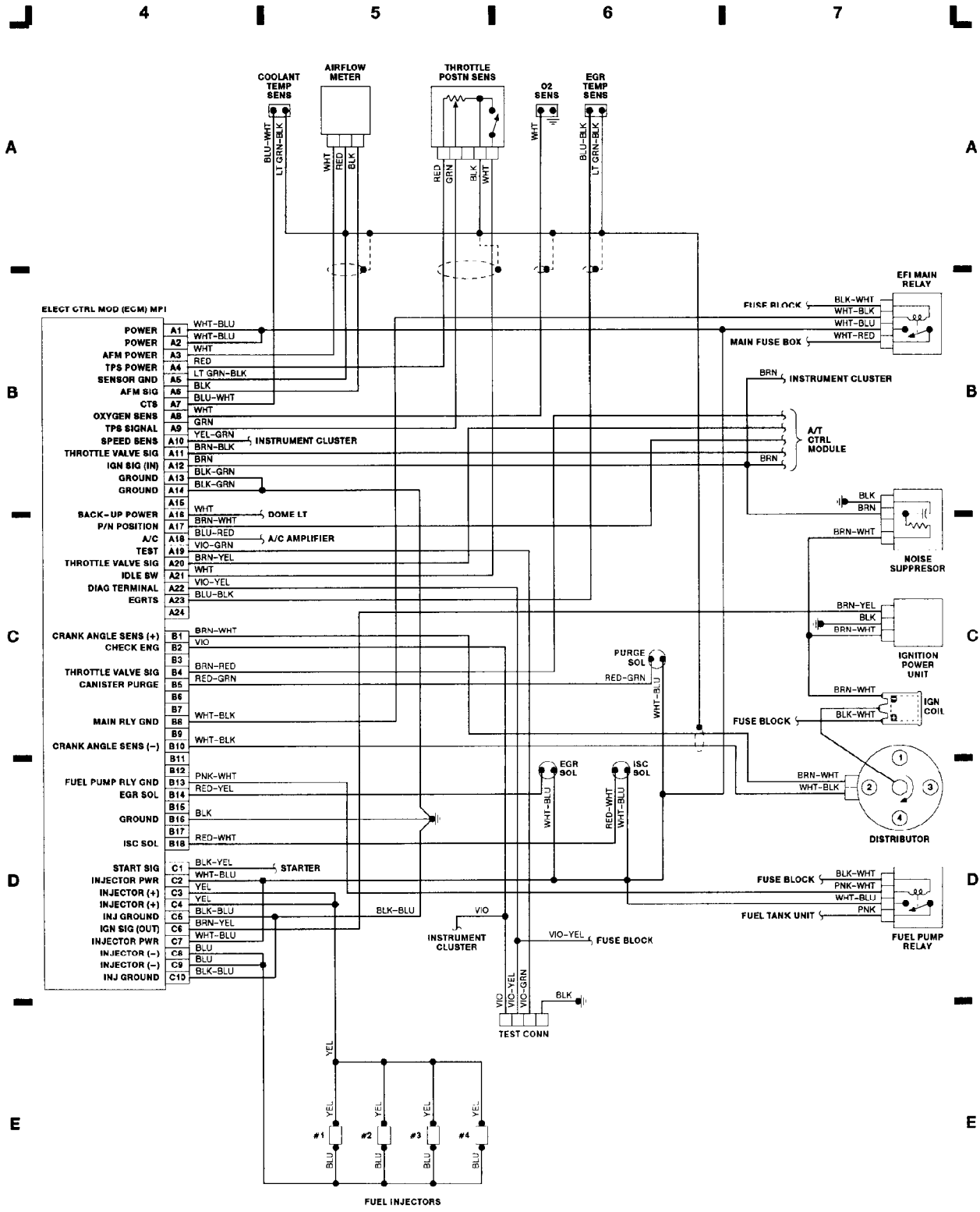

WIRING DIAGRAMS

Fig. 3: Computer Engine Control (TBI) (p. 3)

1989 Suzuki Swift

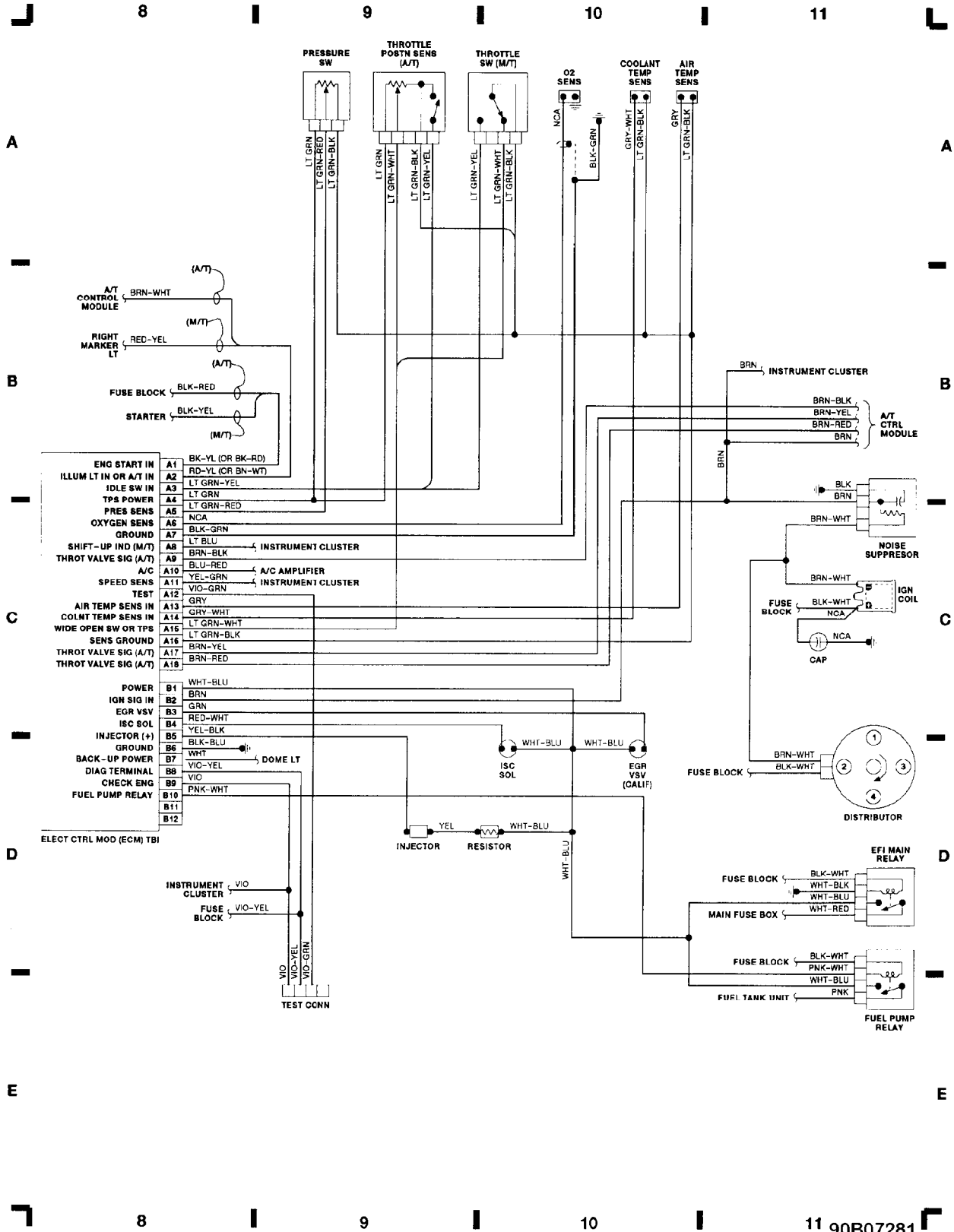

WIRING DIAGRAMS

Fig. 4: Fuse Block (p. 4)

1989 Suzuki Swift

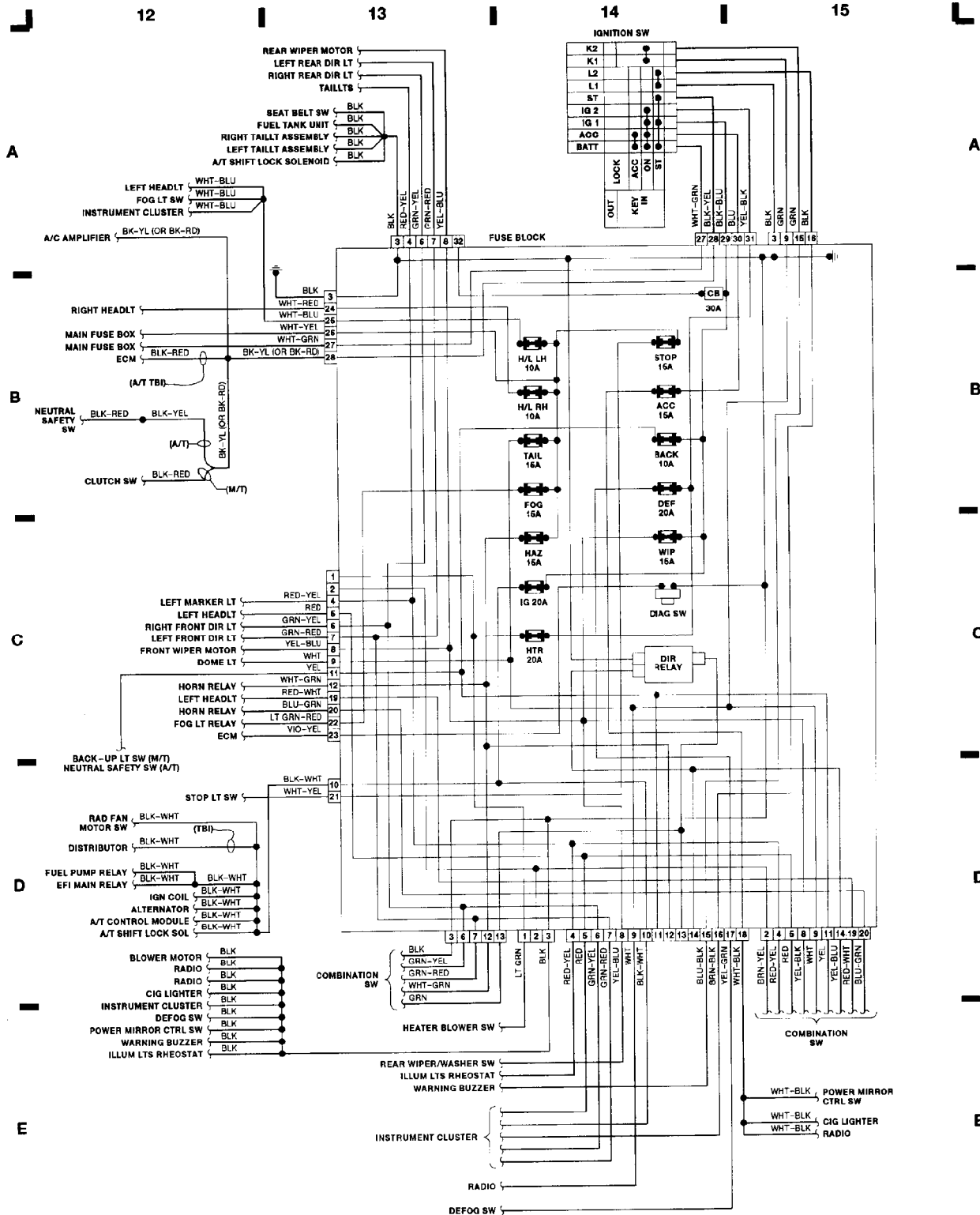

WIRING DIAGRAMS

Fig. 5: Automatic Transmission Control and Steering Column (p. 5)
1989 Suzuki Swift

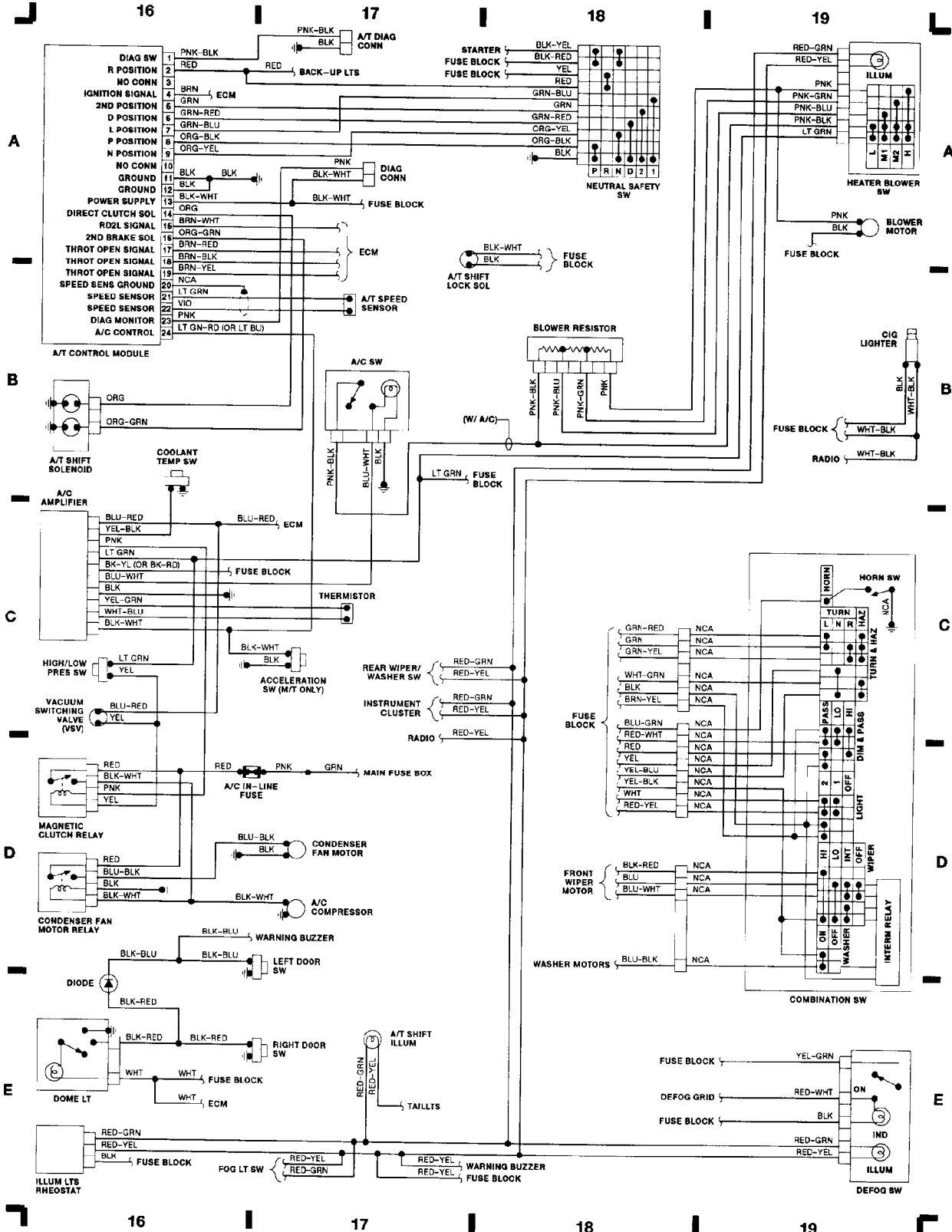

WIRING DIAGRAMS

Fig. 6: Passenger Compartment & Taillights (p. 6)

1989 Suzuki Swift

